

Emergency Safety Shower Water Heater

Tepid Water For Emergency Safety Shower/Eyewash Stations

Features

- **Heavy Duty Construction**
 - ◆ Hydrastone cement lining provides tank longevity
 - ◆ Copper-silicon alloy tappings cannot rust or corrode
 - ◆ High impact composite jacket cannot rust or corrode and eliminates potential damage during installation and transit
 - ◆ 3" thick polyurethane foam insulation reduces standby heat loss by over 24% compared to industry standard 2" insulated tanks
- **Packaged System**
 - ◆ Factory packaged with the Therm-O-Mix® Station/WWM simplifies installation and ensures the safe and reliable supply of tepid water
 - ◆ All electrical operating controls are factory selected and wired to ensure reliable operation
 - ◆ Dial gauge provides visual indication of water temperature and pressure
- **Safety**
 - ◆ Mixing valve designed specifically for emergency drench systems ensures a constant flow of tepid water
 - ◆ Mixing valve prohibits delivery of overheated water to prevent scalding
 - ◆ Provides tepid water even when an accident causes a loss of electric power
 - ◆ Reduces the risk of Legionella because water is stored at an elevated temperature
- **Reliable**
 - ◆ Full five (5) year non pro-rated tank warranty
 - ◆ Each valve is performance tested at the factory to ensure proper operation



ESS Water Heater



The ESS Water Heater is designed specifically for tepid water delivery to an emergency drench system.

A Heavy Duty, Reliable Source For Tepid Water Delivery

The ESS water heater is a packaged system designed to meet the requirements of ANSI Z358.1-2014 for tepid water delivery to an emergency drench system. This heavy-duty water heater is constructed of a carbon steel tank and internally lined with 1/2" thick Hydrastone cement to ensure tank longevity when operating at elevated temperatures, and is fully insulated with 3" thick polyurethane foam to minimize stand-by heat loss. The water heater is packaged with a mixing valve specifically

designed, tested and proven for use in emergency safety shower/face/eyewash applications. The entire package including the mixing valve is factory piped and mounted to the water heater to provide single source responsibility.

When you specify and install an ESS, you will have the confidence in knowing that the owner will be provided with a long lasting, safe and dependable source of tepid water for their emergency drench system needs.

SAFETY STANDARDS

OSHA 29 CFR 1910.151 states the following: When the eyes or body of any person may be exposed to injurious corrosive, toxic, or flammable materials, suitable facilities for quick drenching or flushing of the eyes and body shall be provided within the work area for immediate emergency use.

ANSI Z358.1-2014 Standard states the following: Delivered flushing fluid temperature shall be tepid. This standard also establishes minimum performance and use requirements for eyewash and shower equipment for the emergency treatment of the eyes or body of a person who has been exposed to injurious materials.

The shower must have a minimum of 20 GPM (75.7 L/min) at 30 PSI (2.1 BAR) for 15 minutes of controlled flow [Para 4.1.3]

The eyewash must have a minimum of 0.4 GPM (1.5 L/min) at 30 PSI (2.1 BAR) for 15 minutes of controlled flow [Para 5.1.6]

The eye/face wash must have a minimum of 3.0 GPM (11.4 L/min) at 30 PSI (2.1 BAR) for 15 minutes of controlled flow [Para 6.1.6]

Units must meet all individual performance requirements when all components are operated simultaneously. [Para 7.1]

In circumstances where chemical reaction is accelerated by flushing fluid temperature, a facilities safety/health advisor should be consulted for the optimum temperature. [Para 6.4.6]

HOW DOES THE ESS UNIT ACHIEVE THESE REQUIREMENTS?

The ESS water heater system provides high volume tepid water for safety drench systems by integrating a specially designed mixing valve with a high quality cement lined electric storage water heater. The ESS is designed to maintain 120 gal (454.2 L) of water at 170°F (76.7°C). The volume of water at this temperature is necessary to achieve the final flow rate of 23 GPM (87.1 L/min) for 15 minutes of tepid water. When an emergency drench apparatus is used, the integrated mixing valve blends 170°F (76.7°C) water from the tank with incoming cold water to achieve a continuous flow of approximately 85°F (29.4°C) tepid water to operate simultaneously a safety shower and an eye/face wash fixture.

Note: For 30 GPM (113.6 L/min) shower heads the ESS will provide 75°F (23.9°C) water for 15 minutes.



The ESS satisfies the tepid water requirements for a safety drench system.

The ESS Water Heater package is specifically designed to meet your emergency drench system needs by incorporating the following critical features:

- A** The carbon steel tank is internally lined with specially formulated hydrastone cement and does not require anodic protection. This lining is critical to the longevity of the tank when storing hot water at elevated temperatures.
- B** The mixing valve is specifically designed for emergency safety drench systems and is factory piped and packaged with the water heater tank to simplify installation and ensure a safe and dependable system.
- C** The ESS has 3" foam insulation which reduces stand-by heat losses by over 24% compared to 2" insulated tanks. This provides the owner with a highly efficient and economical solution for emergency drench systems.
- D**

Unlike instantaneous heaters, the ESS is unaffected by the loss of electric power in its ability to provide tepid water. Furthermore, the dial temperature gauge provides the operator with positive visual verification that the unit is at temperature.

MIXING VALVE

OPERATIONAL FEATURES

Packaged with the ESS is a triple redundant, thermostatic pressure balanced valve designed specifically for emergency safety shower/face/eyewash applications. The valve is factory mounted and piped to the water heater. After water flow is activated at the emergency station, the outlet water temperature from the model ESS package will be maintained at 85°F (29.4°C) tepid temperature. The ESS is able to achieve the high volume demand required for a safety drench system by mixing the 170°F (76.7°C) water in the tank with incoming cold water. The mixing valve meets OSHA and ANSI requirements and is capable of providing constant 85°F (29.4°C) output regardless of inlet pressure and temperature variations, and the temperature setting is tamper proof and cannot be inadvertently adjusted in the field. The water temperature is not warm enough to open skin pores and not cold enough to deter usage. The valve is capable of providing a full range of flows from the smallest flow of 0.4 GPM (1.5 L/min) for an eyewash to the combined 23 GPM (87.1 L/min) flow for a simultaneous demand of shower, eyewash, and face wash system.

SAFETY FEATURES

The mixing valve incorporates a pressure sensing controller with a valve actuator that senses the water pressure on both the hot and cold water inlet connections. If hot water pressure is not present then the actuator overrides the mixing



valve and a flow of cold water is allowed. If no cold-water pressure is available at the mixing valve inlet then the hot water port will close to prevent overheated water from exiting the mixing valve. The valve also includes a safety override feature that continuously senses the final mixed water temperature. If the final water temperature is overheated, the valve automatically closes the hot water port and fully opens the cold water port. In any of these fault conditions, the ESS valve will continue to provide a full flow of water as per the ANSI standard with no additional pressure drop.

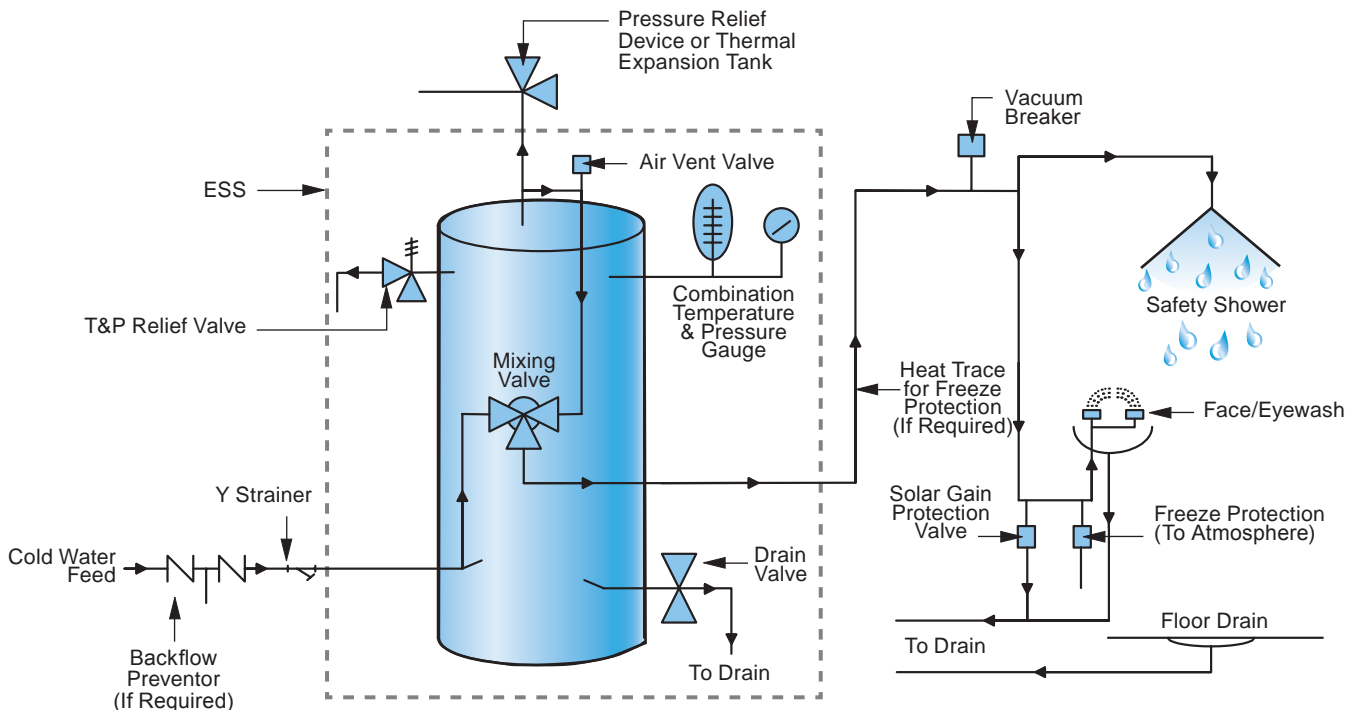

NOTE: For systems requiring recirculation see ThermOmegaTech® IMI for typical pipping schematic.

Outline Dimensions

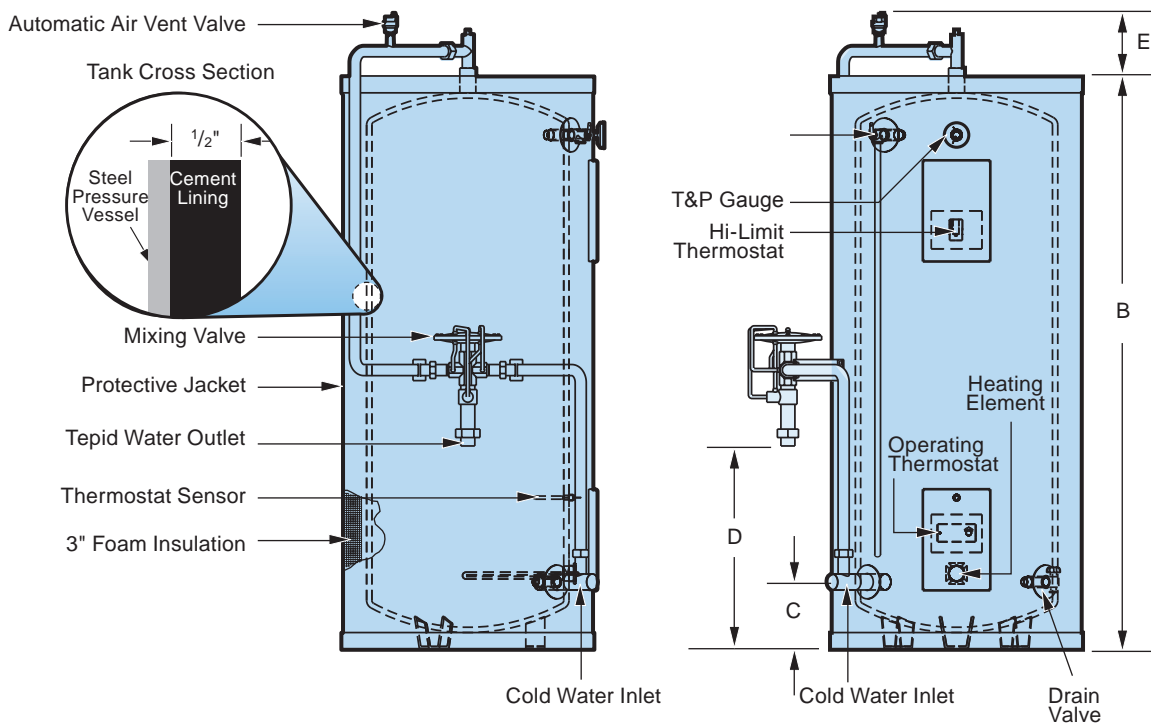
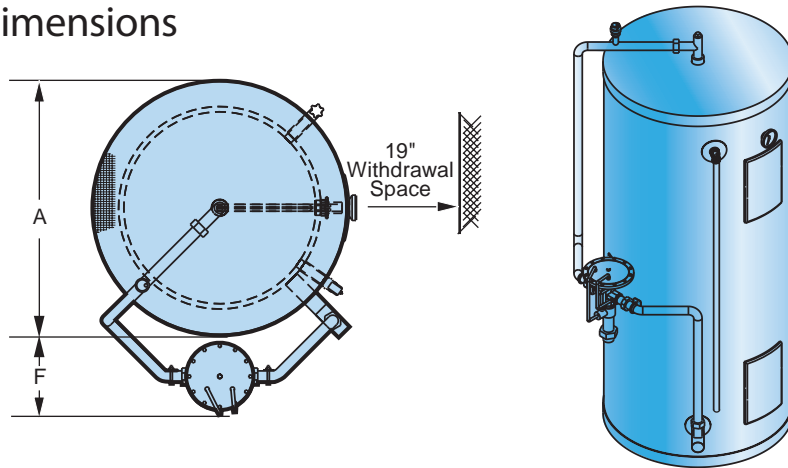

ESS Water Heater Dimensional Data

Storage Capacity (Gallons)	Base Model Number	Dimensions (inches)						Shipping Weight (lbs.)
		A Diameter	B Height	C Floor to Inlet	D Floor to Outlet	E Piping Height	F Floor to T&P	
120	ESS	30	69.25	8	24	8	10	875

Note: Alternate storage capacities are available for smaller or larger requirements. Please consult factory for sizing requirements.

Why you need a safety shower/eyewash station

Water that is too cold can discourage workers from washing down for the required 15 minutes. (It can cause hypothermia)
 Water that is too hot can cause third degree burns in as little as one second and can accelerate a harmful chemical reaction
 What you need is an easy-to-use, reliable system that provides water at the recommended temperature

ESS Water Heater Specifications

Tank:	Hydrastone Cement Lined Steel	Mixing Valve Cv:	10.0
Storage Capacity:	120 Gallons (see note)	Pressure Drop at 20 GPM:	4 psi
Orientation:	Vertical	Minimum Supply Pressure:	30 psi
Voltages:	120 thru 600 Volt	Hi-Limit:	190°F
Phase:	1 or 3 Φ	Design WP:	150 psi
Cold Water Inlet Size:	1 1/2" Female NPT	Design TP:	300 psi
Tepid Water Outlet Size:	1 1/4" Female NPT	Elements:	Copper Sheathed
Drain Size:	3/4" GHT	Insulation:	3" Polyurethane Foam
Relief Valve Size:	3/4" Female NPT	Tank Warranty	
Relief Valve Type:	T&P, 210°F, 150 psi	Standard:	5 Year Non Pro-Rated
Thermostat Range:	100-180°F	Optional:	10 Year Non Pro-Rated
Piping:	Copper Tubing	Electrical Warranty:	1 Year
Note:	Alternate storage capacities are available for smaller or larger requirements. Please consult factory for sizing requirements.		
		Jacket:	High Impact Colorized Composite
		Color:	Brown and Tan

Formulas To Solve For:

TO SOLVE FOR TEPID WATER PRESSURE DROP:

$\frac{GPM^2}{Cv^2} = \Delta P$ The ESS mixing valve Cv = 10.0
 Example: Determine pressure drop across ESS with a 20 GPM flow

$$\frac{20^2}{10^2} = \frac{400}{100} = 4 \text{ psi pressure drop}$$

Note: The ESS valve maintains the same pressure drop even when the valve is in cold water bypass mode.

TO SOLVE FOR THE PERCENTAGE OF HOT WATER TO FINAL MIXED WATER:

$$\frac{M-C}{H-C} = \% \text{ of hot to mixed water}$$

Example: Determine the percent of 170°F hot water required for a mixed temperature of 85°F when cold water is 50°F

$$\frac{85-50}{170-50} = \frac{35}{120} = 29\% \text{ Therefore, 29\% of the mixed 85°F water stream must be 170°F.}$$

M = Mixed water temperature
 C = Cold water temperature
 H = Hot water temperature

METRIC CONVERSION

- Liters x 0.2641 = Gallons
- Gallons x 3.79 = Liters
- Gallons x 0.003785 = m³
- m³ x 264.2 = Gallons
- 1°C ΔT = 1.8°F ΔT
- °F = (°C x 1.8) + 32
- °C = (°F - 32) x 0.556
- psi x 0.06896 = Bar
- Bar x 14.5 = psi
- psi x 6.86 = kPa
- kPa x 0.1456 = psi
- Kg/cm² x 14.28 = psi
- psi x 0.07 = Kg/cm²
- Lbs x 0.4536 = Kg
- Kg x 2.2 = Lbs
- Watts/Sq.Cm. x 6.4 = Watts/Sq.In.
- Watts/Sq.In. x 0.155 = Watts/Sq.Cm.

Watts	Recovery Rating in GPH 50-170°F	Amperage Ratings Single Phase Voltages				
		120 V	208 V	240 V	277 V	480 V
1500	5.1	13	7	6	5	N.A.
3000	10.2	N.A.	14	13	11	6
4000	13.6	N.A.	19	17	14	8
4500	15.3	N.A.	22	19	16	9
6000	20.5	N.A.	29	25	22	13

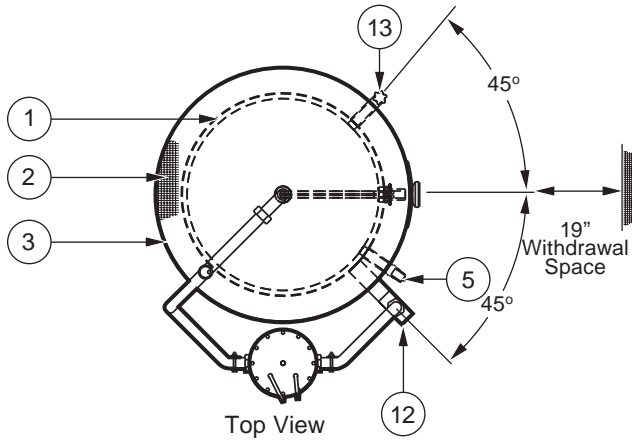

Top View

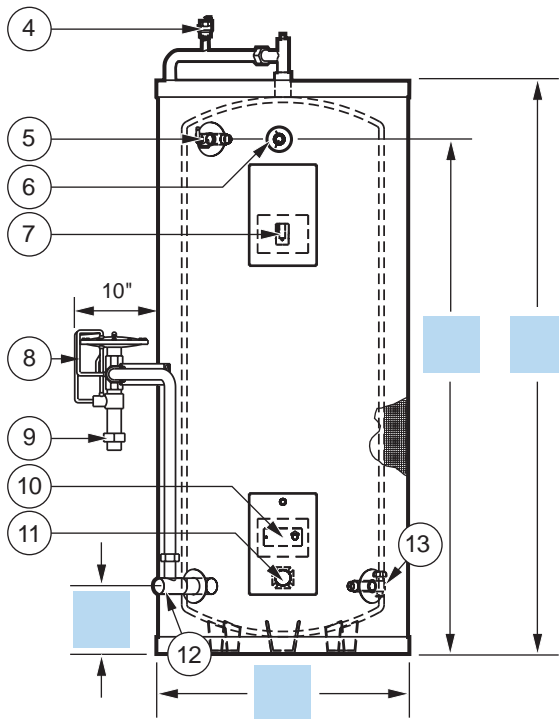

Front View

Notes:

1. Storage tank rated for 150 psi WP
2. ASME rated T&P relief valve factory installed and piped to 12" from floor
3. All electrical controls are factory wired and tested
4. Mixing valve (pc. 8) is factory set, calibrated and tested to deliver 85°F water

PC Number	Description
1	Hydrastone cement Lined Tank
2	3" Polyurethane Foam Insulation
3	Corrosion Resistant Jacket
4	Air Vent Valve
5	Relief Valve Connection
6	Dial Temperature Pressure Gauge
7	Hi-Limit Thermostat
8	Mixing Valve
9	Tepid Water Outlet
10	Tank Operating Thermostat
11	Heating Element
12	Cold Water Inlet
13	Drain Connection

General Characteristics

	Gallon Storage Capacity
	Total KW Rating
	Volts
	Phase
	50/60 Hertz
	85°F Mixing Valve Set Temperature
	Full Load Amperage
	1 1/2" MNPT Cold Water Inlet Size
	1 1/4" FNPT Tepid Water Outlet Size
	Dry Weight (Lbs.)
	Wet Weight (Lbs.)
	Cold Water Inlet
	Drain Connection

Tepid Water Delivery

GPM for min @ 85°F

Recovery Rating

GPH from to (°F ΔT)



Tepid Water Heating System

353 Ivyland Road Warminster, PA

Model No.:

Location:

QTY:

Job Name:

Date:

ESS Number Designation

Family Designation	Valve Criteria					
	Storage Capacity	Tepid Water Temperature	Standard Ratings KW	Tank Type	Voltage/Phase/Hz	
	0 = 120 Gal.	0 = 85°F 1 = 75°F	0 = 1.5 1 = 3 2 = 4 3 = 4.5 4 = 6 5 = 10 6 = 7 7 = 12 8 = 6.3	0 = SL (Hydrastone Cement Lined)	0 = 240-1-60 1 = 480-3-60 2 = 208-1-60 3 = 277-1-60 4 = 120-1-60 5 = 480-1-60 6 = 208-3-60	
389	-	0	3	0	0	0 - 000

Note: If other criteria is needed consult ThermOmegaTech®

Example: **389-003000-000** The ESS Water Heater emergency tepid water delivery system with a storage capacity of 120 Gallons, 85°F set point of the mixing valve and a 4.5 KW rating. Storage tank is lined with Hydrastone cement and operates at 240 Volts single-phase power.

Benefits of a tepid water safety shower/eyewash station:

- Encourage user to wash down long enough to be effective
- Prevent further injury
- Get employee back to work fast
- Provide employee with a feeling of security about his work environment

Occupational Injuries

- Over 12,000 cases of non fatal chemical burns involving days away from work annually
- Non fatal chemical burns result in a median of 2 days away from work
- Average of 118 fatalities annually from exposure to caustic, noxious, or allergenic substances
(Source: Bureau of Labor Statistics)

Variables Attributable to Third Degree Burn*	
Water Temp. (F°)	Exposure Time
120	9.5 minutes
125	2.0 minutes
130	30 seconds
140	15 seconds
150	1.8 seconds
158	1.0 seconds

*From studies conducted by Lewis & Love (1926; Wu. Yung-Chi, N.B.S. (1972); Dr. M.A. Stoll, for U.S. Navy (1979)

Master Specification: ESS Water Heater

JOB NAME _____

ENGINEER _____

REPRESENTATIVE _____

CONTRACTOR _____

GENERAL & APPROVALS

Contractor shall supply and install with all codes and authorities having jurisdiction a factory packaged water heater for emergency drench application. System shall be model No. _____ Emergency Tepid Water Delivery System. Unit shall be designed to operate at _____ volts, _____ phase, and 60 hertz with a maximum load of _____ watts. The system shall be specifically designed for tepid water delivery to emergency safety shower/face/eyewash fixtures in accordance with ANSI Z358.1. Packaged system shall consist of a long-life electric water heater with integrally mounted, factory supplied, calibrated and performance tested, triple redundant thermostatic pressure balanced mixing valve system. Unit shall be supplied ready for electrical and plumbing service connections. Field assembled systems shall not be considered as equals. Substitutions must meet the following specifications minimum to be considered for approval as equal.

CONSTRUCTION

- A. The electric water heater shall be a 120 gallon capacity vertical carbon steel tank lined with 1/2" thick Hydrastone cement to ensure maximum operating life at elevated temperatures. Heater shall not require any type of anodic protection.
- B. Tank inlet and outlet water connections shall be a minimum of 1 1/4" NPT non-ferrous copper-silicon/brass. Steel tank tappings will not be acceptable.
- C. Tank shall be covered by a minimum 3" thick polyurethane foam insulation to minimize stand-by heat loss over the life of the system. Due to the increased cost of operation, systems with less than 3" insulation will not be acceptable.
- D. Outer protective jacket shall be a dent resistant composite jacket to resist rust and corrosion.
- E. Tepid water temperature control shall be provided by an integrally piped and packaged thermostatic mixing valve. Valve shall be specifically designed, tested and manufacture-designated for use in emergency safety drench applications. Delivery water set point shall be 85°F. (Optional 75°F temperature available.)
- F. Temperature safety system shall consist of a diaphragm operated valve actuator to ensure a continuous delivery flow of tepid water. The valve shall monitor pressure on both cold and hot water inlets. On loss of cold water pressure the valve shall prevent delivery of hot water to avoid scalding. On loss of hot water pressure, the valve shall allow the full ANSI required flow of cold water to the emergency safety fixture.
- G. Water pressure drop across the system must not exceed 5psi at 20 GPM flow, mixing valve must have a Cv rating not less than 10.0.
- H. The system shall be supplied complete with all electrical operating controls. Safety devices and accessories shall include but not be limited to:
 - 1. Low watt density immersion heating element
 - 2. Adjustable immersion temperature controller
 - 3. Safety high limit switch with manual reset
 - 4. Dial temperature and pressure gauge
 - 5. ASME temperature and pressure relief valve
 - 6. Automatic air vent valve

In addition, this packaged system shall be supplied with the following optional features:

- Option _____
- Option _____
- Option _____

The water heater manufacturer shall warranty all electrical components against defects in workmanship and material for a period of one (1) year from date of start-up, and the pressure vessel for a full five (5) years Non Pro-Rated (**Optional Specification:** full ten (10) years Non Pro-Rated) from date of start-up, provided that the unit is started within three (3) months of date of shipment and installed and operated within the scope of the tank design and operating capability. Each water heater shall be shipped with a complete set of installation and operating instructions including spare parts list and approved drawings.



ThermOmegaTech®, Inc.
353 Ivyland Road
Warminster, PA 18974

1-877-379-8258
www.ThermOmegaTech.com

