

DTV

DRAIN TEMPERING VALVE



BENEFITS

- Compliant with drain temperature limitations of plumbing codes
- Prevents damage to PVC piping due to over-temperature conditions
- Minimizes water waste
- Easy to install
- Adaptable to almost any drain size

DESIGN FEATURES

- Rugged, clog resistant valve design
- Install using standard pipe fittings and tools
- Operates in any orientation
- Modulates to conserve cooling water
- Effluent tempering capacity limited only by cold water flow rate through DTV

TYPICAL USES

- Humidifier discharge to sewer/drain
- Commercial dishwashers/warewashers
- Boiler blowdown drain lines
- Autoclave discharge
- Any excessively hot effluent flow to sewer/drain

OPERATION

The **DTV** can be used in applications where a high temperature discharge flow to a drain/sewer must be tempered with cold water. The **DTV** is installed into the drain line such that the hot effluent passes over the thermal actuator of the **DTV** and this thermal actuator controls the cold water inlet port. If the hot effluent is above the specified setpoint, the **DTV** opens to allow injection of cold water. As the hot effluent cools, the **DTV** automatically modulates to reduce the cold water inlet flow. At about 10°F below the full open temperature, the cold water inlet is fully closed to conserve water.

The **DTV** provides a convenient, economical, and easy to use method of tempering hot effluent flows. Since the **DTV** is open only when the effluent exceeds the specified setpoint temperature, it also conserves water by automatically turning off cold water when not needed.



1" DTV

¾" DTV

½" DTV

TYPICAL INSTALLATIONS

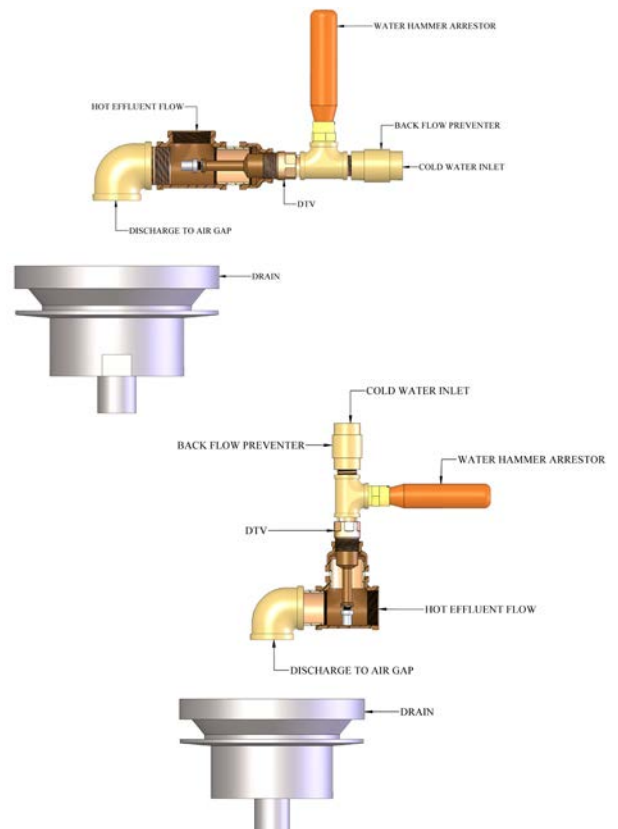

DTV

DRAIN TEMPERING VALVE



PARTS & MATERIALS

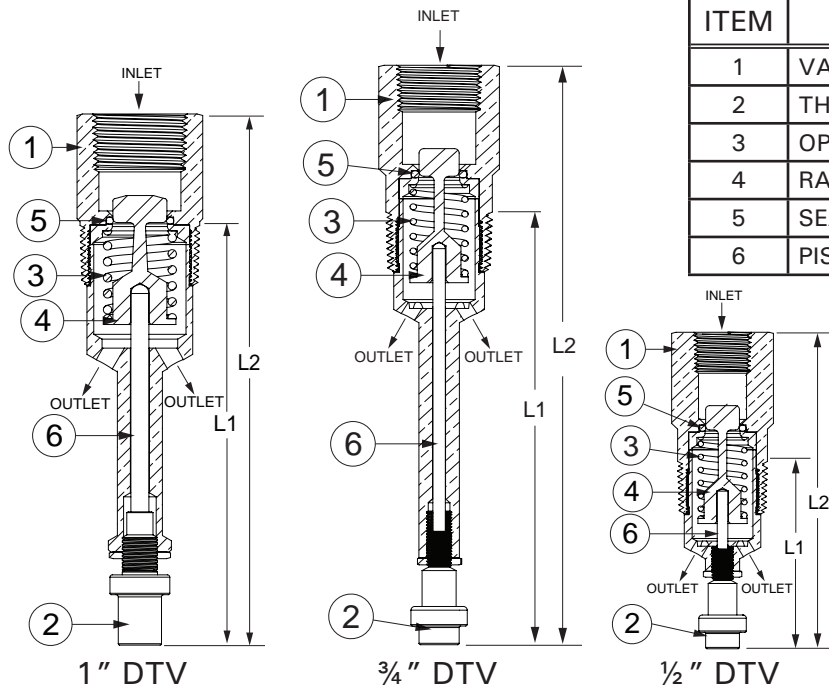

ITEM	DESCRIPTION	MATERIAL
1	VALVE BODY	Brass or 300 Series SS
2	THERMAL ACTUATOR	300 Series SS
3	OPERATING SPRING	300 Series SS
4	RAM-TYPE PLUG	300 Series SS
5	SEAT SEAL	PTFE
6	PISTON	300 Series SS

DIMENSIONS & CAPACITIES

SIZE (NPT)		L1		L2		Weight		C _v	Maximum Inlet Water Pressure	Maximum Temperature
Water Inlet	Drain Connection	in	mm	in	mm	Lb	Kg			
1/2"	1"	2.9	73	4.9	124	1.1	0.5	2.0	125 PSIG (8.6 BAR)	250°F (121°C)
3/4"	1"	5.9	149	7.9	200	1.2	0.5	2.0		
1"	1-1/4"	5.8	148	7.4	187	1.5	0.7	4.0		

ORDERING

Part Number ¹	Description
325-000000-XXX	1/2" DTV Valve
325-100000-XXX	1/2" DTV Valve (Stainless Steel)
326-000000-XXX	3/4" DTV Valve
326-100000-XXX	3/4" DTV Valve (Stainless Steel)
327-000000-XXX	1" DTV Valve
327-100000-XXX	1" DTV Valve (Stainless Steel)

SAMPLE CALCULATION

How much effluent can be tempered with a 1" DTV valve?

1) Flow capacity through cold water port of 1" DTV with C_v = 4.0:

$$CW \text{ gpm} = C_v \times \sqrt{\text{pressure drop}}$$

Assume 50 psig cold water pressure, drain pressure = 0 psig

$$CW \text{ gpm} = 4 \times \sqrt{50} = 28.3 \text{ gpm}$$

Assume for this example:

cold water temp = 60°F (CT)

hot effluent temp = 212°F (HT)

max. allowable drain temp = 140°F (MT)

2) Maximum effluent flow (gpm) that can be tempered:

$$CW \times \frac{(MT-CT)}{(HT-MT)}$$

$$MT-CT = 80$$

$$HT-MT = 72$$

$$\text{Maximum effluent flow rate} = 28.3 \times \frac{80}{72} = 31.4 \text{ gpm}$$

NOTES

- Full open temperatures "XXX" available: 120°, 125°, 130°, 140°.
 - Other temperatures are available, consult our engineers for more information.
 - Note: Closing temperature is typically 10°F below opening temperature.**
- Cold water inlet typically requires a back-flow preventer.
- Warranty information disclosed at www.thermomegatech.com/terms-conditions/



ThermOmegaTech®, Inc.
353 Ivyland Road
Warminster, PA 18974

1-877-379-8258
www.ThermOmegaTech.com



DTV
Rev:7/10/18